

28" SERIES BLOCKS

Top - 28"

Volume = 8.55 cft
 Weight = ±1223 lbs
 C of G = 15.06"

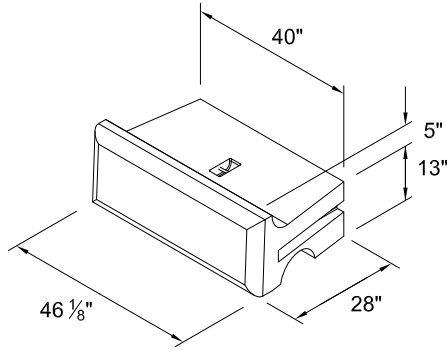

Half Top - 28"

Volume = 4.13 cft
 Weight = ±591 lbs

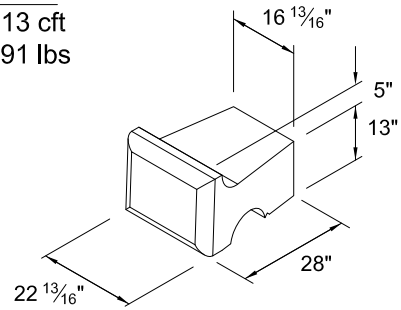

Middle - 28"

Volume = 11.40 cft
 Weight = ±1630 lbs
 C of G = 14.18"

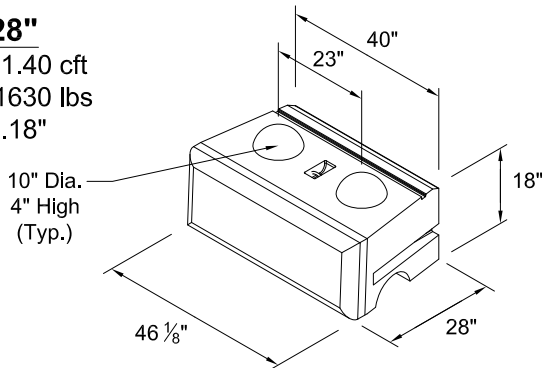

Half Middle - 28"

Volume = 5.34 cft
 Weight = ±764 lbs

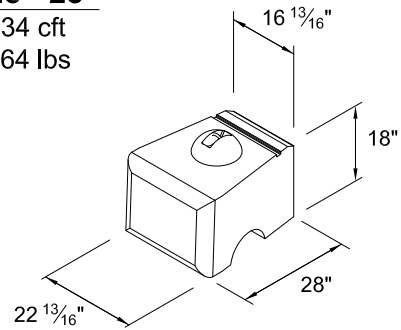

Bottom - 28"

Volume = 12.36 cft
 Weight = ±1768 lbs
 C of G = 14.23"

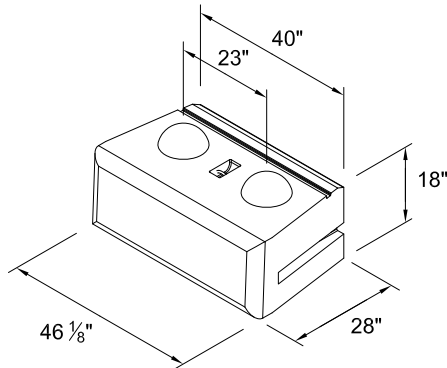

Half Bottom - 28"

Volume = 5.79 cft
 Weight = ±827 lbs

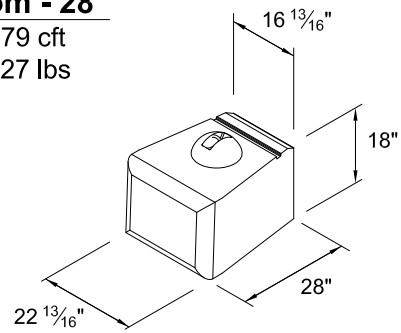

23" End Block

Volume = 6.79 cft
 Weight = ± 970 lbs
 C of G = 12.29"

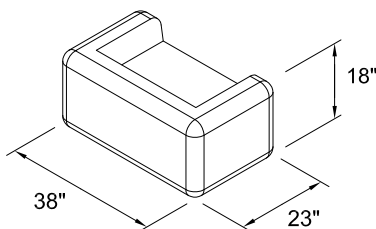

9" Bottom Block

Volume = 6.40 cft
 Weight = ±915 lbs
 C of G = 14.20"

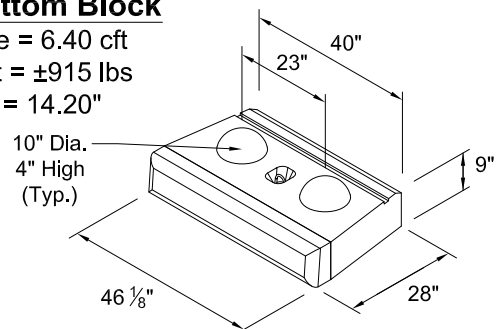

NOTES:

Volume and Center of Gravity (C of G) calculations are based on the blocks as shown.

Center of Gravity is measured from the back of the block.

Half blocks may include a fork lift slot on one side.

Actual weights and volumes may vary.

Weight shown is based on 143 pcf concrete.

DRAWN BY J. JOHNSON	01/08/10	Redi-Rock® International, LLC	
CHECKED BY			
APPROVED BY		DRAWING FILE 28in Series Block Details 010810.dwg	REVISION ---
ISSUE DATE		SCALE NO SCALE	SHEET NO. 1 OF 1